



Technical information

Clamping device Ratio-Clamp®

- + Force absorption in both directions.
- + Suitable for horizontal and vertical movement.
- + Immediate clamping without any further rod movement.
- + No return movement necessary for release.
- + Operational safety guaranteed by helical disc springs.
- + Certified by TÜV SÜD and DGUV Test.

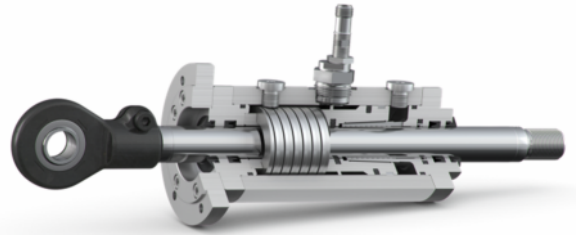

Table of contents

1	Use	1
1.1	Intended use.....	1
1.2	Improper use.....	1
2	Principle of operation.....	2
2.1	Clamping device Ratio-Clamp® released.....	2
2.2	Clamping device Ratio-Clamp® locked	2
2.3	Clamping device Ratio-Clamp® overloaded.....	2
2.4	Releasing clamping device Ratio-Clamp®	2
3	Selecting the right clamping device	2
3.1	Equipment.....	2
3.2	Technical data	3
4	Selection and status monitoring	3
5	Requirements for the rod	4
6	Functional test.....	4
7	Safety	4
8	Operating conditions.....	4
9	Energy balance	4

1 Use

The clamping device Ratio-Clamp® safely clamps all types of piston rods and round rods from a standstill.

- Will continue to clamp during controlled or uncontrolled pressure drops, and even in case of an emergency shutdown or a power failure.
- Can be used as restraining device for stepless load-holding over unlimited periods of time.
- Fixates axles during production processes to save energy, or to maintain an exact position when external forces are acting on the rod.

Ratio-Clamp® is a registered trademark of Herbert Hänchen GmbH & Co. KG.

1.1 Intended use

The clamping device Ratio-Clamp® is used in

- Presses in accordance with EN 693
- Test stands
- Machine tools
- Mobile elevating work platforms
- Injection moulding machines in accordance with EN 201.

It is used as a **separate unit** or as an **attachment** to a hydraulic cylinder. All types of Ratio-Clamp® can be installed on hydraulic cylinders. For this purpose, the piston rod has to be lengthened depending on the length of the clamping device. This means that Ratio-Clamp® devices can be combined with Hänchen hydraulic cylinders, ISO 6020-1 or ISO 6020-2 standard cylinders, and with many cylinders from other manufacturers.

They can be attached with a fixed flange, or with a collar flange to compensate an axle offset.



Figure 1: Hydraulic cylinder with built-on Ratio-Clamp®

1.2 Improper use

Do not use clamping device Ratio-Clamp®:

- For clamping directly from the movement. The Ratio-Clamp® is not a brake.
- Clamping rotating rods or shafts.



2 Principle of operation

The clamping device Ratio-Clamp® operates by the friction force principle.

2.1 Clamping device Ratio-Clamp® released

As long as the hydraulic release pressure is applied, the rod can move freely in both directions.

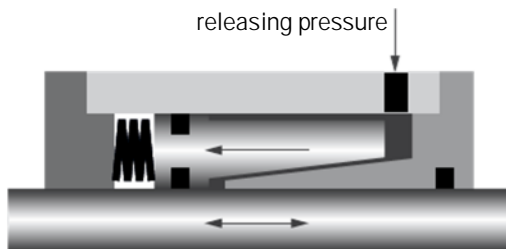

Figure 2: Clamping device Ratio-Clamp® released

2.2 Clamping device Ratio-Clamp® locked

When the release pressure drops, the force stored in the springs is released and causes the rod to be clamped. This occurs either due to a controlled pressure reduction or where the hydraulic system suffers a loss of pressure through an emergency switch off, power loss or damage to the system.

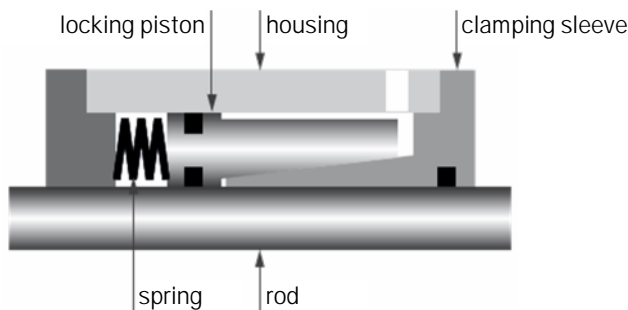

Figure 3: Clamping device Ratio-Clamp® locked

The clamping force is maintained for an unlimited period of time and without an additional power supply.

2.3 Clamping device Ratio-Clamp® overloaded

A short overload with slippage of the rod is admissible, no damaging of the piston rod or the clamping device occurs!

2.4 Releasing clamping device Ratio-Clamp®

The releasing pressure opens the clamping device, allowing the piston rod to move freely once again. No return movement is necessary for releasing the clamping device Ratio-Clamp®.

3 Selecting the right clamping device

3.1 Equipment

The term equipment is used for the characteristics of Ratio-Clamp® it is divided into the characteristics

categories releasing pressure, sealing system and certification.

3.1.1 Releasing pressure and holding load

The releasing pressure is the pressure required to release the clamping device.

The **basic release pressure** is between a minimum pressure, which depends on the dimensioning, and the maximum admissible pressure of 160 bar.

The **reduced release pressure** is about 30 % below this level, and is especially suitable for applications with low supply pressure, for example in tool machines.

The maximal **holding load** depends on the release pressure an can be selected in HäKo. These values are valid for use with mineral oil. Using other fluids, the holding load may be lower.

3.1.2 Sealing system

The sealing system describes the designs and combinations of sealing elements in the Ratio-Clamp®.

The basic type of Ratio-Clamp® uses the **sealing system Servocop®**. The primary seal is working on the rod to be clamped and is suitable for piston rod speeds of up to 1 m/s.

For especially sensitive applications, the **sealing system with a pressure piston seal** can be used. In this system, the rod moves without pressurized seals when released. Thus, the system's sliding friction is considerably lower than that of the Servocop® version, and is not influenced by the releasing pressure. This version is e.g. suitable for test applications with piston rod speeds of up to 2 m/s.

3.1.3 Certification

Ratio-Clamp® is certified by TÜV SÜD as a safety element.

The Ratio-Clamp® version with the **DGV test certificate** is approved for the application in hydraulic presses according to EN 693 or injection moulding machines according to EN 201.

3.1.4 Locking

The locking mechanism of a Ratio-Clamp® **with spring power** is normally based on energy stored in springs, which is used to clamp a rod.

In order to realize even very high holding loads, it is possible **to lock** the clamping device **hydraulically**. In this case, the device uses hydraulic pressure instead of spring power to generate the locking effect. On your request, we can also configure a locking system that uses hydraulic pressure instead of springs.



3.2 Technical data

	Ratio-Clamp [®]		Ratio-Clamp [®] with reduced releasing pressure		Ratio-Clamp [®] with DGUV Test certification		Ratio-Clamp [®] with pressure piston seal	
+ Sealing system	Servocop [®]		Servocop [®]		Servocop [®]		Pressure piston seal	
+ Releasing pressure	Basis design		Basis design		Basis design		Basis design	
+ Certification	TÜV certification		TÜV certification		DGUV Test		TÜV certification	
+ Locking	With spring power		With spring power		With spring power		With spring power	
Rod Ø f7 in [mm]	F axial max. in [kN]	p release min. in [bar]	F axial max. in [kN]	p release min. in [bar]	F axial max. in [kN]	p release min. in [bar]	F axial max. in [kN]	p release min. in [bar]
16	10	60	8	50				
18	12.5	55	8	35	6.25	55	12.5	75
20	14	55	9	40	7	55	14	75
22	17	70	12	45	8.5	70	17	90
25	20	70	15	50	10	70	20	90
28	31.5	90	25	65	15.75	90	31.5	120
30	40	105	30	75	20	105	40	135
32	40	60	30	45	20	60	40	90
36	45	75	32	50	22.5	75	45	100
40	50	80	38	55	25	80	50	100
45	65	70	45	50	32.5	70	65	90
50	80	90	55	60	40	90	80	110
56	90	75	60	50	45	75	90	100
60	100	75	70	55	50	75	100	100
63	100	85	60	55	50	85	100	110
70	140	80	100	55	70	80	140	110
80	180	90	130	65	90	90	180	110
90	200	65			100	65	200	85
100	250	75			125	75	250	95
110	300	65			150	65	300	90
120	330	70			165	70	330	90
125	350	75			175	75	350	90
140	450	65			225	65		
160	750	90						

4 Selection and status monitoring

When a Ratio-Clamp[®] is employed together with a hydraulic cylinder, the Ratio-Clamp[®] must firstly be released by hydraulic pressure applied to the releasing connection. Only then may the rod be moved by the application of hydraulic pressure to the piston surfaces in the cylinder. Even when the clamping device is used without a cylinder, it is important for the clamping device to be completely released before the rod starts moving.

After a particular position has been reached, the Ratio-Clamp[®] is re-engaged when no further pressure is applied to connections A or B of the cylinder. This sequence occurs automatically when a control block is employed.

Connected between the changeover valves and the Ratio-Clamp[®] /cylinder unit, the control block ensures functional control in the correct sequence and thereby saves resources for the user by minimising switching circuitry.

Using the control block in horizontally cylinder-mounting position is reasonable.

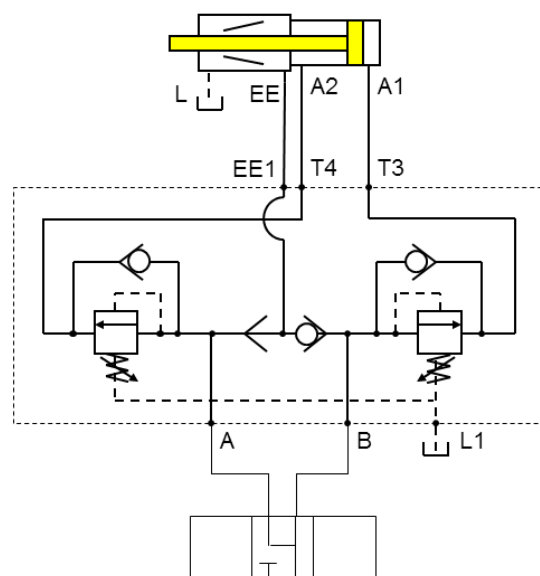

Figure 4: Functional diagram control block

The respective status – piston rod locked or released – can be queried using inductive proximity switches. The optional additional diagnostic output monitors the function of the switch and the supply line.

A proximity switch is included by default. Optionally, it is also possible to use two proximity switches. Hänchen's advantage: Protection against damage thanks to limited length of engagement.

5 Requirements for the rod

When installing the Ratio-Clamp[®], the round rod to be clamped must fulfil the minimum requirements as shown in figure 5. A honed rod is recommended.

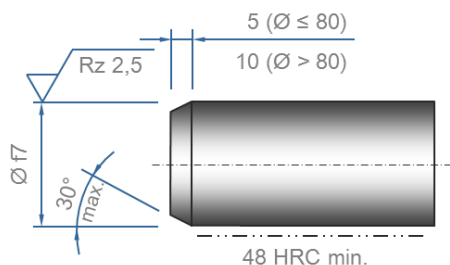

Figure 5: Minimum requirements for the rod to be clamped

6 Functional test

Have the Ratio-Clamp[®] inspected by Hänchen after two million clamping procedures. If it carries out safety functions, a regular inspection is required.

Depending on operational demands, at regular intervals, at least every six months or after longer periods of non-operation:

- Check tightness.
- Make sure that holding load is as indicated in the documentation.

7 Safety

The Ratio-Clamp[®] clamping device is a reliable technological solution and is applied where risks due to external forces or loads have to be considered in accordance with **EN ISO 13849-1**. These may not lead to a hazardous movement of the cylinder.

In case of fluctuations, loss or return of the pressure energy, the clamping device locks round rods strained by an axial load.

- As a substitute for non-return valves if risks occur due to external force in de-energised state.
- As additional safety element for drives strained by gravity, if the load causes hazards, e.g. in restraining

devices when lowering a load associated with hazards.

- As a fixing element if the cylinder has internal leaks, e.g. over the piston seal or over gap seals.
- As a secure position retention element in case of a line break.

8 Operating conditions

Detailed information on installation and start-up is available for download at <http://www.haenchen-hydraulic.com>.

If not otherwise specified, observe the following operating conditions:

- Operation with hydraulic oils according to DIN 51524 with ISO VG 32 to VG 68. Other liquids, e.g. water, water emulsions, fire-resistant fluids on request.
- Recommended cleanliness classes 19/16/13 according to ISO 4406 for clamping device Ratio-Clamp[®] with normal sealing elements.
- Use in roofed spaces
- Relative air humidity < 70%
- Operating temperatures: -30 °C to +80 °C
- Maximum releasing pressure 160 bar

9 Energy balance

Regardless of hydraulics and electronics, Ratio-Clamp[®] will hold the piston rod tight and offers a number of advantages in comparison with other technical solutions:

- Clamping without energy supply
- Cost savings thanks to no energy loss
- Safe clamping in case of system failure
- Clamping for an unlimited period of time
- Accurate locking in any position
- Safety in extreme conditions such as heat or cold

Locking options for round rods in comparison	Electronic control	Blocking ports	Ratio-Clamp [®]
Energy efficiency	-	+	+
Accuracy of position	+	-	+
Independence of external factors	+	-	+
Time and effort	-	+	+